



INSTALLATION MANUAL

FT-FOTR-16VD-ST-S

16-Channel Digital Duplex Baseband Video Transmitter and Receiver With Reverse Data Transmission for PTZ Cameras



PACKAGE CONTENTS

This package contains:

- One each FT-FOTR-16VD-ST-S 16-channel baseband video transmitter and receiver
- Two 5VDC power supplies
- One installation manual

PRODUCT DESCRIPTION

The FT-FOTR-16VD-ST-S fiber optic transmitter/receiver supports the transmission of sixteen baseband video channels and a single reverse data signal over one strand of single-mode fiber optic cable. This product is compatible with all NTSC and PAL video signals. Power, optical signal, video signal and data signal are easily inspected through LED indicators directly on the units. The transmitter and receiver combination supports transmission distances for optical loss budgets of less than 18 dB.

SPECIFICATIONS

FT-FOTR-16VD-ST-S

Specifications (Typical)

1. Optical Wavelength	1310nm / 1550nm
2. Fiber Type	Single-mode 9/125 μ m
3. Maximum Link Distance	12.5 miles
4. Connector	Simplex ST
5. Acceptable Loss Budget	18 dB
6. Number of Video Inputs	16
7. Video Connector	BNC Female
8. Transmitter Input Impedance	75 Ω unbalanced
9. Receiver Output Impedance	75 Ω unbalanced
10. Video Bandwidth per Channel	0Hz – 6.5MHz
11. Video SNR	>60 dB
12. Differential Gain	<1%
13. Differential Phase	<1°
14. Tilt	<1%
15. Data Rate	0 – 300Kbps
16. Data Connector	Terminal Block
17. Data Interface	RS485, RS422 or RS232
18. Baud Rate Per Channel	0 – 100Kbps
19. Bit Error Rate	<10 ⁻⁹
20. Power Supply	5VDC
21. Power Consumption	<10W
22. Operating Relative Humidity	0 – 95% non-condensing
23. Operating Temperature	14°F – 122°F
24. Dimensions	9.1"x8.2"x2.2" per unit
25. Weight	2.6 lb. per unit

INSTALLATION AND OPERATION



This symbol is intended to alert the user to the presence of important operating and maintenance (servicing) instructions.



This symbol is intended to alert the user to the presence of “dangerous voltage” within the product’s enclosure that may be of sufficient magnitude to constitute a risk of electrical shock.

CAUTION: To reduce the risk of electrical shock do not remove the cover or back of this unit. No user serviceable parts are inside.

CAUTION: To prevent electric shocks and risk of fire hazards, do not use other than specified power source.

1. UNPACKING and HANDLING

Each unit is shipped assembled and factory tested.

Ensure that all accessories are removed from the container before discarding packing material

2. MECHANICAL INSPECTION

Inspect the front and rear of the equipment for shipping damage. Make sure the equipment is clean, and no connectors are broken, damaged, or loose. If equipment appears to be damaged or defective please contact your distributor or Fibertronix at 1-610-429-1511 for assistance.

3. WIRING CONNECTIONS

Transmitter Front and Rear Panels

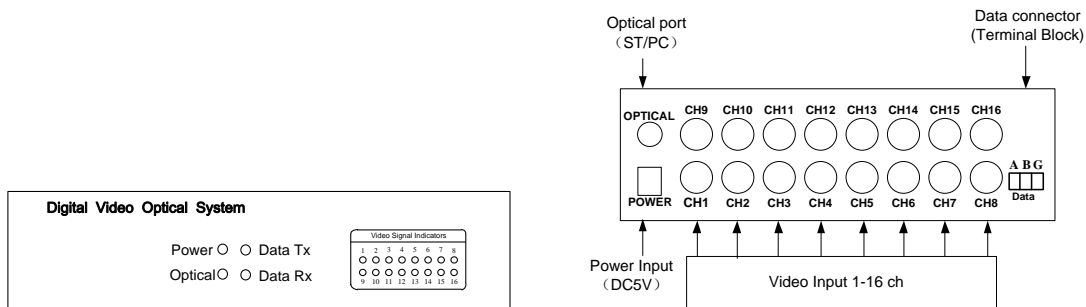

Receiver Front and Rear Panels

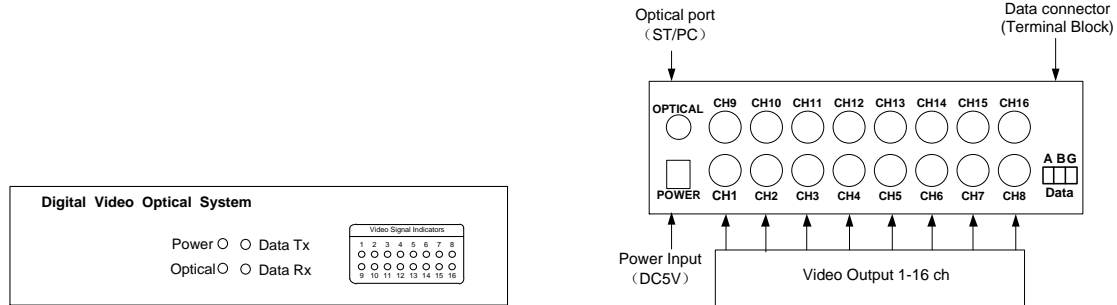

Terminal Block

A: Data Output +
B: Data Output -
G: Ground Connection



- Plug the included power supplies in a 120VAC outlet. Each power supply's DC output adaptor connects respectively to the power input of the transmitter and receiver.
- Connect the transmitter and receiver's optical connectors with an ST/PC patch cable. The transmitter and receiver's Link Indicator Lights will indicate optical signals are transmitted and received normally.
- Connect the video source (e.g., camera) to the transmitter's video input port using quality 75Ω coaxial cable with BNC connectors.
- Connect the video monitor to the receiver's video output port using quality 75Ω coaxial cable with BNC connectors.
- Connect the data ports using the RS485 terminal block. Be sure the wiring configurations are consistent with the diagram above for the transmitter and receiver as well as the PTZ camera.
- Indicator lights:
 - Power LEDs display power status. A normal display indicates the input power supply is correct. An irregular display indicates the wrong input power or a problem with the unit's circuits.
 - Optical LEDs display whether the optical signals are being transmitted and received correctly.
 - Video Signal LEDs indicate the video status
 - Data TX and Data RX LEDs respectively display data output and data input status.

4. SPECIAL ATTENTION

- a. Only use the power supplies included with these units. The use of other power supplies may damage the transmitter and/or receiver and void the warranty.
- b. The loss of optical fiber should be less than 18 dB. Any loss greater than 18 dB will compromise the receiver's ability to get the optical signals from the transmitter.
- c. Adhere to the equipment's in-door operating temperature and humidity specifications. Failure to do so may damage the equipment and void the warranty.

5. TROUBLESHOOTING

- a. No picture after applying power – (i) check all connectors and cables are securely connected to the video source, monitor, transmitter and receiver; (ii) ensure all power supplies are providing the correct voltage and current.
- b. No image or poor image quality – determine if the optical signal loss is greater than 18 dB.
- c. The picture has ripples – (i) check to see if the camera's power supply is experiencing AC ripple, if so a filter may be required; (ii) determine if the monitor is faulty; (iii) determine if other peripheral equipment is causing ripple and if so make the necessary adjustments.
- d. The picture background continuously changes color – a fluorescent lamp's magnetic field may cause color roll, therefore, reduce the number of fluorescent lamps or increase the distance between the camera and the lamps.
- e. The picture appears smeared – (i) the camera's power supply voltage level may be unstable, therefore, try another power supply; (ii) ensure the camera and/or monitor cables are correctly connected and/or the cables are of the correct impedance.
- f. Other interference may require a Fibertronix ground loop isolation filter.
- g. Data communications are not working – (i) ensure all cables and connectors are secured and (ii) ensure all terminal block connections are consistent as specified in the wiring diagram for the transmitter and receiver and the PTZ camera.
- h. Additional troubleshooting assistance can be found on-line at www.fibertronix.com in addition to support from Fibertronix sales engineers at 1-610-429-1511.