



## INSTALLATION MANUAL

### **FT-FOTR-16V-ST-S** **16-Channel Digital Simplex** **Baseband Video Transmitter and Receiver**



## PACKAGE CONTENTS

This package contains:

- One each FT-FOTR-16V-ST-S 16-channel baseband video transmitter and receiver
- Two 5VDC power supplies
- One installation manual

## PRODUCT DESCRIPTION

The FT-FOTR-16V-ST-S fiber optic transmitter/receiver supports the transmission of sixteen baseband video signals over one strand of single-mode fiber optic cable. This product is compatible with all NTSC and PAL video signals. Power, optical signal and video signal are easily inspected through LED indicators directly on the units. The transmitter and receiver combination supports transmission distances for optical loss budgets of less than 18 dB.

## SPECIFICATIONS

### FT-FOTR-16V-ST-S

Specifications (Typical)

1. Optical Wavelength	1310nm
2. Fiber Type	Single-mode 9/125 $\mu$ m
3. Maximum Link Distance	12.5 miles
4. Connector	Simplex ST
5. Acceptable Loss Budget	18 dB
6. Number of Video Inputs	16
7. Video Connector	BNC Female
8. Transmitter Input Impedance	75 $\Omega$ unbalanced
9. Receiver Output Impedance	75 $\Omega$ unbalanced
10. Video Bandwidth per Channel	0 – 6.5MHz
11. Video SNR	>60 dB
12. Differential Gain	<1%
13. Differential Phase	<1°
14. Tilt	<1%
15. Power Supply	5VDC
16. Power Consumption	<10W
17. Operating Relative Humidity	0 – 95% non-condensing
18. Operating Temperature	14°F – 122°F
19. Dimensions	9"x5.8.1"x2.2" per unit
20. Weight	2.6 lb. per unit

# INSTALLATION AND OPERATION



This symbol is intended to alert the user to the presence of important operating and maintenance (servicing) instructions.



This symbol is intended to alert the user to the presence of “dangerous voltage” within the product’s enclosure that may be of sufficient magnitude to constitute a risk of electrical shock.

**CAUTION: To reduce the risk of electrical shock do not remove the cover or back of this unit. No user serviceable parts are inside.**

**CAUTION: To prevent electric shocks and risk of fire hazards, do not use other than specified power source.**

## 1. UNPACKING and HANDLING

Each unit is shipped assembled and factory tested.

Ensure that all accessories are removed from the container before discarding packing material

## 2. MECHANICAL INSPECTION

Inspect the front and rear of the equipment for shipping damage. Make sure the equipment is clean, and no connectors are broken, damaged, or loose. If equipment appears to be damaged or defective please contact your distributor or Fibertronix at 1-610-429-1511 for assistance.

## 3. WIRING CONNECTIONS

- a. Plug the included power supplies in a 120VAC outlet. Each power supply’s DC output adaptor connects respectively to the power input of the transmitter and receiver.
- b. Connect the transmitter and receiver’s optical connectors with an ST/PC patch cable. The transmitter and receiver’s Link Indicator Lights will indicate optical signals are transmitted and received normally.
- c. Connect the video source (e.g., camera) to the transmitter’s video input port using quality 75Ω coaxial cable with BNC connectors.
- d. Connect the video monitor to the receiver’s video output port using quality 75Ω coaxial cable with BNC connectors.
- e. When working normally, the transmitter’s power indicator will be lighted green.
- f. When working normally, the receiver’s power indicator will be lighted yellow.
- g. Optical Indicator LED displays whether the optical signals are correctly transmitting/receiving.
- h. Video Signal Indicator LED displays the video status.
- i. Data TX and Data RX Indicator LEDs respectively display data output and data input, but are not used in this model.

## Transmitter Front and Rear Panels

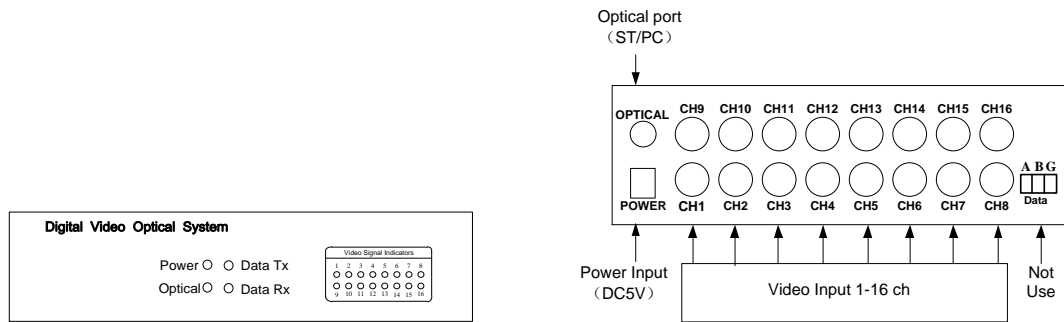

## Receiver Front and Rear Panels

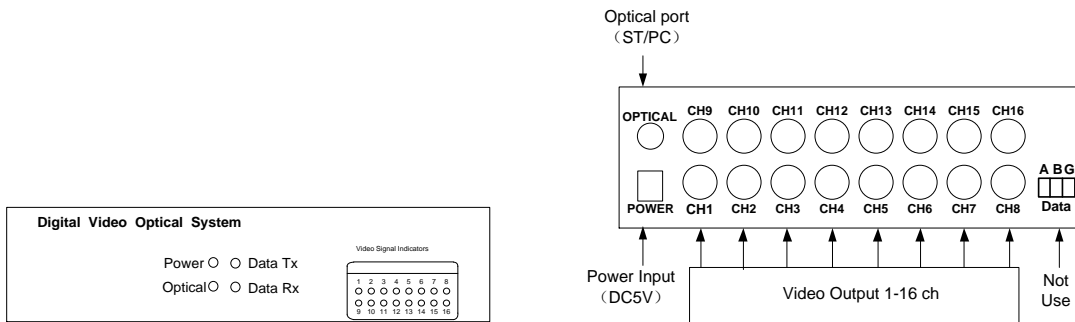

## 4. SPECIAL ATTENTION

- Only use the power supplies included with these units. The use of other power supplies may damage the transmitter and/or receiver and void the warranty.
- The loss of optical fiber should be less than 18 dB. Any loss greater than 18 dB will compromise the receiver's ability to get the optical signals from the transmitter.
- Adhere to the equipment's in-door operating temperature and humidity specifications. Failure to do so may damage the equipment and void the warranty.

## 5. TROUBLESHOOTING

- No picture after applying power – (i) check all connectors and cables are securely connected to the video source, monitor, transmitter and receiver; (ii) ensure all power supplies are providing the correct voltage and current.
- No image or poor image quality – determine if the optical signal loss is greater than 18 dB.
- The picture has ripples – (i) check to see if the camera's power supply is experiencing AC ripple, if so a filter may be required; (ii) determine if the monitor is faulty; (iii) determine if other peripheral equipment is causing ripple and if so make the necessary adjustments.
- The picture background continuously changes color – a fluorescent lamp's magnetic field may cause color roll, therefore, reduce the number of fluorescent lamps or increase the distance between the camera and the lamps.
- The picture appears smeared – (i) the camera's power supply voltage level may be

unstable, therefore, try another power supply; (ii) ensure the camera and/or monitor cables are correctly connected and/or the cables are of the correct impedance.

- f. Other interference may require a Fibertronix ground loop isolation filter.
- g. Additional troubleshooting assistance can be found on-line at [www.fibertronix.com](http://www.fibertronix.com) in addition to support from Fibertronix sales engineers at 1-610-429-1511.