



FT-HHRX-870-1-*

FTTH Mini Optical Node



Operation Manual

INSTALLATION AND OPERATION



This symbol is intended to alert the user to the presence of important operating and maintenance (servicing) instructions.



This symbol is intended to alert the user to the presence of “dangerous voltage” within the product’s enclosure that may be of sufficient magnitude to constitute a risk of electrical shock.

CAUTION: To reduce the risk of electrical shock do not remove the cover or back of this unit. No user serviceable parts are inside.

CAUTION: To prevent electric shocks and risk of fire hazards, do not use other than specified power source.

CAUTION: To prevent electric shocks and risk of fire hazards, do not expose this equipment to rain or moisture.

CAUTION: Pay attention to NEC articles 810-21, 820-22, and 820-40 that provide guidelines for proper grounding.

CAUTION: This unit may emit harmful invisible laser radiation. Do not view directly any laser optical emissions. Viewing the laser with certain optical instruments such as a microscope or magnifier may pose an eye hazard. The laser is classified as a Class 1M per IEC/EN 60825-1/A2:2001 and complies with FDA/CDRH, 21 CFR 1040.10 and 1040.11 except for deviations pursuant to Laser Notice No.50 dated 26 July, 2001.

1. UNPACKING and HANDLING

Each unit is shipped assembled and factory tested.

Ensure that all accessories are removed from the container before discarding packing material

2. MECHANICAL INSPECTION

Inspect the front and rear of the equipment for shipping damage. Make sure the equipment is clean, and no connectors are broken, damaged, or loose. If equipment appears to be damaged or defective please contact your distributor or Fibertronix at 1-610-429-1511 for assistance.

Description

The FT-HHRX-870-1 is a state of the art fiber optic node designed for FTTH applications. It offers flexibility in operation and maintenance. The GaAs FET technology provides low distortion and a flexible input level with low power consumption and surge protection. It features a 1310nm FP, DFB, and CWDM return transmitter. The AGC function is specially designed to simplify installation and network maintenance while compensating for changes in optical power within -6dBm~+2dBm to provide stable RF output levels.

Features

- Working wavelength: 1200~1600nm
- 1000MHz Passband, Bi-Directional Transmission, and Return Optical Transmitter
- Broad Optical Input Range (-8dBm~+2dBm)
- pHEMT GaAs FET Technology
- Local or Remote Power Supply
- Die-cast Aluminum Housing for Heat Dissipation Performance

Block Diagram

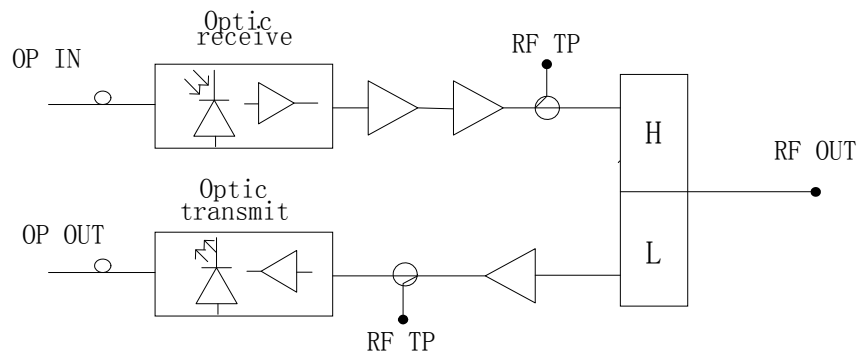

Specifications

Item		Unit	Description	Remark
Optical	Input Optical Power Range	dBm	-8 ~ +2	
	Optical Test Point	V/mW	+1V/mW	
	Equivalent Input Noise Current		<4pA /√H	
	Work Wavelength	nm	1200~1600	
	Optical Connector		SC/APC	others on request
RF	Bandwidth	MHz	54/70/85 ~ 870/1000	
	Flatness	dB	±0.75	
	Impedance	Ω	75	
	RF Output Level	dBmV	24±2	@ -6dBmW, OMI=3.7%/ch
	RF Return Loss	dB	≥18	
	RF Test Point	-dB	20±0.75	
	RF Output Stability	dB	±0.5	
	CNR	dBc	>46	@ -6dBmW
	CTB	dBc	>70	@ -6dBmW
CSO	dBc	>65	@ -6dBmW	
General	Work Temperature		- 40~+60	
	Power Supply Voltage	VDC	+12 ~ +24	
	Power Consumption	W	4	
	Surge Protection	KV	6	

Reverse Path

Item		Unit	Description	Remark
Optical	RF Test Point (@Return Optical Transmitter)	-dB	20±0.75	
	Laser Type		FP , DFB or CWDM	
	Optical Output Power	dBmW	≥0	
	Optical Power Test Point	V/mW	+1V/mW	
	Optical Wavelength	nm	1310	
	CNR	-dBc	>45	
	CTB(FP)	-dBc	>45	
	CSO(FP)	-dBc	>45	
RF	Passband	MHz	5 to 42/55/65	
	Flatness	± dB	0.75	
	Impedance	Ω	75	
	RF Return Loss	- dB	16	
	RF Input Level	dBmV	20	

Installation

1. Unpacking

Open box and inspect for damages. Locate optical node, power supply, and users manual

2. Mounting

The **FT-HHRX-870-1** chassis is designed for installation on a wall or other suitable flat surface. We recommend an installation plan that puts the **FT-HHRX-870-1** chassis near the fiber and coax paths and routing power as required to that location either using the supplied power adaptor or using your own DC coax powering solution.

The **FT-HHRX-870-1** node is very low power consumption so thermal dissipation is generally not an issue. The Mini-node will dissipate small amounts of heat into the surface to which it is attached and into the air. Do not attach to a surface that is heated by other equipment or processes. Do not restrict the airflow around the chassis by closely covering the unit. Do not position the unit where heat egressed from other nearby equipment may ingress heat into the unit.

3. Making Connections

Connect the 12V coaxial cable power supply to “PWR IN” port located on the top left of the optical node via coaxial cable. Upon plugging in power supply to an outlet, “PWR ON” LED will illuminate.

Depending on which **FT-HHRX-870-1** you purchased, all connections must be SC/APC or FC/APC. For all connections, first be sure to clean the connectors prior to connecting them to the optical node.

The “RF OUT” port located at the top left of the optical node is to be connected with the distribution system by coax.